

MOTOPLASTIC, S.A.

Molí de la sal, 1 - 08403 Granollers (Barcelona) SPAIN

Tel. 34 93 849 06 33 - Fax 34 93 849 09 88





info@puig.tv - info@puigusa.com

www.puig.tv - www.puigusa.com

INSTRUCCIONES DE MONTAJE - MOUNTING INSTRUCTIONS - MONTAGEANLEITUNG

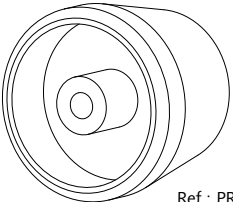
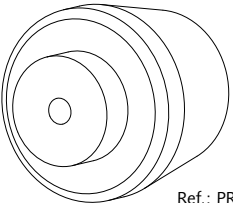
PROTECTOR HORQUILLA PHB19 ADAPTABLE A / FRONT-AXLE PHB19 ADAPTABLE TO DUCATI SCRAMBLER DESERT '17-

Ref.: 20042N

ID.	PIEZA / PART	QTY.
1	 Ref.: PROFOR70-2-0070	1
2	 Ref.: PROFOR40-2-0785	1
3	 Ref.: VARIFO16-1-0016	1
4	 Ref.: TUZBM6000000024	2
5	 Ref.: ARANDEPD125-054	2
6	 Ref.: TAPAFINAL17-18	2

Created by www.ridisseny.com

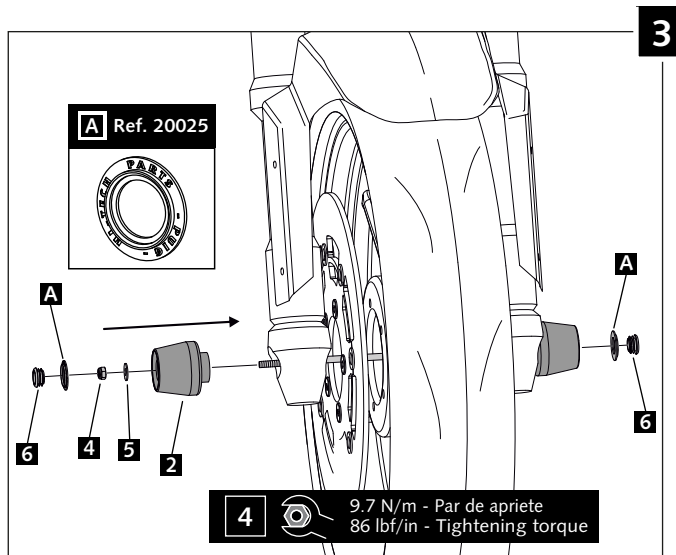
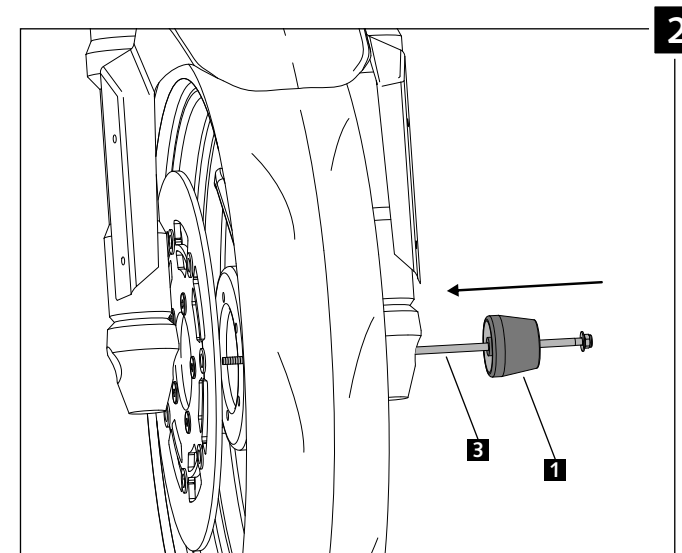
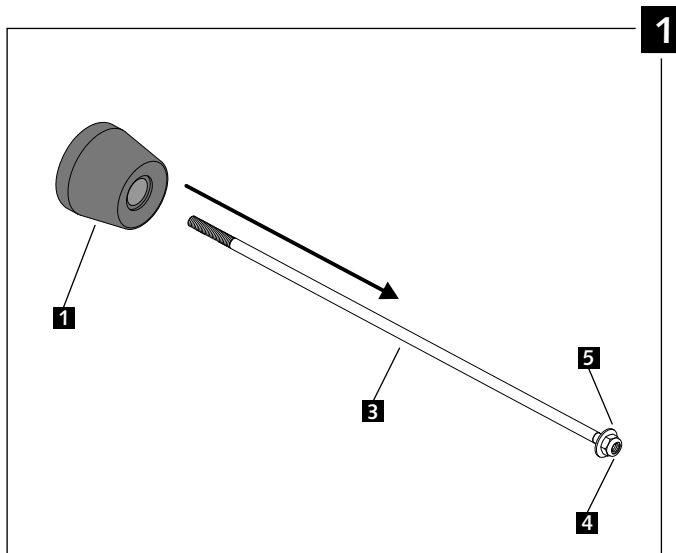

CONSULTAR EN NUESTRA PAGINA WEB LA DISPONIBILIDAD DEL VIDEO DE MONTAJE DE ESTA REFERENCIA.
CONSULT OUR WEBSITE THE VIDEO MOUNT AVAILABILITY OF THIS REFERENCE.

